

REDBALL[®]

Application System TNT



Parts and Operator's
Manual



Application System

TO THE OWNER

Congratulations on your selection of a Redball® Application System. Redball® Application Systems have earned a reputation of providing accurate, uniform applications of materials throughout the U.S. and Canada.

Redball® Application Systems have been designed to provide many years of profitable and dependable service. To assure maximum performance of your system, it is mandatory that you thoroughly study the operator's manual and follow its recommendations. Proper operation and maintenance are essential for safety, to maintain performance, and to maximize the life of the machine.

It is the owner's responsibility to:

- Operate and maintain this application system in a safe manner and in accordance with all applicable local, state, and federal codes and/or laws; and in compliance with labeling instructions furnished by the supplier of the chemical being used.
- Make sure each and every operator has read the operator's manual and thoroughly understands safe and correct operating procedures.
- Make sure unauthorized people do not operate or are not in the vicinity of the application system while it is in operation.
- Maintain the application system in accordance with the maintenance schedule in this manual. Furthermore, as additional technology becomes available, the owner is responsible for improving the safety, and reliability of the system.
- Fulfill all warranty obligations so as not to void the warranties. The warranty section at the back of this manual outlines the warranty policy of Redball, LLC and its suppliers.

Redball, LLC reserves the right to make product improvements to the equipment at any time. Redball, LLC shall not be obligated to make such changes to application systems already in service.

* The owner, manager and/or operator is responsible for safe, accurate operation and maintenance of the Redball® Application System

TABLE OF CONTENTS

Safety Instructions	Section A
Safety First	1
Safety Instructions for Operation	2
Installation and Mounting	Section B
Applicator System Mounting	1
Installing Auger Bracket	1
Plumbing	2
Electrical Hook-Up	2
Operation Instructions	Section C
System Overview	1
Jug Hook-Up	1
Application	2
Calibration	Section D
Calibration	1
Calibration Guide	2
Service, Maintenance, Storage, and Troubleshooting	Section E
Service & Maintenance	1
Clean-Up	1
Storage	1
Troubleshooting	2
Parts and Schematics	Section F
Warranty	Section G

Application System

NOTES

Application System - Safety Instructions

Section A

Application System - Safety Instructions

Section A

SAFETY FIRST

Accidents can be prevented by recognizing the causes or hazards before an accident occurs..... and doing something about them.

Regardless of the care used in the design and construction of this equipment, there are some areas that cannot be completely safe guarded without interfering with the accessibility and efficiency of operation.



THIS MESSAGE ALERT SYMBOL IDENTIFIES IMPORTANT MESSAGES IN THIS MANUAL. WHEN YOU SEE THIS SYMBOL, BE ALERT TO THE POSSIBILITY OF PERSONAL INJURY AND CAREFULLY READ THE MESSAGE THAT FOLLOWS.

In this manual and on labels used on the machine the words “**DANGER**”, “**WARNING**”, and “**CAUTION**”, are used to indicate the following:

DANGER: Indicates an imminently hazardous situation that, if not avoided, will result in death or serious injury.

WARNING: Indicates a potentially hazardous situation that, if not avoided, could result in death or serious injury.

CAUTION: Indicates a potentially hazardous situation that, if not avoided, may result in minor or moderate injury.



THIS MESSAGE ALERT SYMBOL IDENTIFIES INFORMATION THAT MUST BE HEEDED FOR PROPER OPERATION OF EQUIPMENT AND TO PREVENT DAMAGE OR DETERIORATION OF THE EQUIPMENT.

In this manual the words “**IMPORTANT**” and “**NOTE**” are used to indicate the following:

IMPORTANT: Highlights information that must be heeded.

NOTE: A reminder of other related information that needs to be considered.

Application System - Safety Instructions

Section A

1. DO NOT ALLOW ANYONE TO OPERATE THIS REDBALL® APPLICATION SYSTEM UNTIL HE OR SHE HAS READ THIS MANUAL AND IS COMPLETELY FAMILIAR WITH ALL SAFETY AND OPERATION PROCEDURES.



WARNING

Observe the IMPORTANT SAFETY INSTRUCTIONS listed below at all times!

THE BEST KIND OF SAFETY IS A CAREFUL OPERATOR



CAUTION

Always wear protective clothing, goggles, respirator and gloves when handling chemicals.



DANGER

Safety instructions furnished by chemical manufactures must be followed exactly to prevent serious harm to individuals and / or the environment.



WARNING

Observe all Federal and State EPA regulations and all Local, State and Federal codes and / or laws regarding licensing, handling, storage, transportation, application and waste disposal of chemicals.

2. Do not allow the following people to operate or repair this equipment.
 - * Children
 - * Irresponsible persons
 - * People under the influence of alcohol, medications or other drugs that can cause drowsiness or impaired judgement.
 - * Persons unfamiliar with equipment or people who are careless or unfamiliar with safe operating procedures.

Application System - Safety Instructions

Section A

3. People who are allergic to any of the chemicals used must never be allowed in or near the application system.
4. Always park on a level surface, and lock the tractor brakes, or block the tires, before making adjustments or repairs.
5. Engage all safety locks on implements before making adjustment or repairs. Ex. Cylinder locks on lift mechanism.
6. Before operating this equipment, thoroughly inspect the unit to insure it is in good working order.
7. Do not operate this unit if any defect or malfunction exists.
8. Verify that the application system is securely mounted to the implement and the implement is securely hitched to the tractor.
9. If any device on the application system itself is not functioning properly, DO NOT use the application system. Remove it from service until it has been properly repaired by a qualified service technician.
10. Do not replace components or parts with those other than genuine Redball® Factory Service Parts. To do so may reduce the effectiveness of safety features or decrease the accuracy of the unit.

11. Read the Operator Instructions section of this manual for further necessary information relating to the safe operation of the applicator.



IMPORTANT

Certain chemicals can be very corrosive and may oxidize steel over a period of time. This weakens steel parts and can cause failure to perform as intended. Periodically check unit for corrosive damage.

Application System - Installation and Mounting

Section B

Application System - Installation and Mounting

Section B



IMPORTANT

Remove the TNT unit and remaining contents from the shipping carton and check for damaged parts prior to set-up. Also check for parts which may have come loose during shipping. Report any damage or missing parts immediately to Redball, LLC.

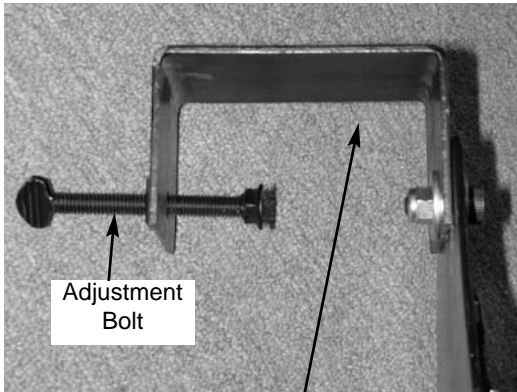

Hanger Bracket

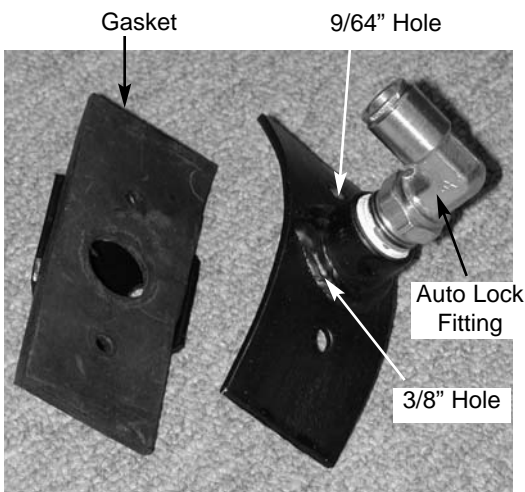

Auger Bracket

The following is a guide, but an exact mounting design will depend on owner preference and location. You should, however, be able to achieve a good mount with the following directions.

Mounting the Unit

Be sure to mount or locate the unit in a secure area. The area should be convenient to access, but safe from traffic, tipping or access by small children.

1. The TNT unit is equipped with a hanger bracket. Mount the unit where it is convenient, but safe from traffic.
2. Tighten the bolt on the back of the hanger bracket to secure the unit.

Installing Auger Bracket

To install the auger bracket on an auger 16' or longer, mount the auger bracket approximately 4-6' from the grain intake end of the auger. For augers 8-16' long, mount the auger bracket 2-4' from the grain intake end.

1. Place the auger bracket and the gasket on the top of the auger, make sure the gasket is between the auger and the bracket. Drill two 9/64" holes through the auger case. Mount the auger bracket with #10 self-tapping screws.
2. Once the auger bracket is secure, remove the auto-lock coupler from the middle of the bracket and drill one 3/8" hole through the center hole on the auger bracket. Take care not to damage the threads in the bracket.
3. Re-attach the auto-lock fitting to the auger bracket. Insert the discharge hose into the elbow fitting. **Be sure to push the hose all of the way into the port to have a secure lock.**

Application System - Installation and Mounting

Section B

PLUMBING

Suction Hose

1. Cut 5 feet from the 25 feet of 3/8" OD tubing that has been supplied with the TNT unit.
2. Connect the 5 foot 3/8" OD intake line to the port on the female quick coupler on the suction tube assembly. Be sure to push the hose all of the way into the port to have a secure lock.
3. Connect the other end of the intake hose on the suction tube assembly by inserting it into the "in" port on the pump.

Discharge Hose

1. Connect the remaining 20 foot piece of 3/8" OD Discharge hose into the metering valve/on-off valve assembly. Be sure to push the hose all of the way into the port to have a secure lock.
2. Route the hose as direct as possible to the auger, and secure it to the auger with wire ties and/or tape.

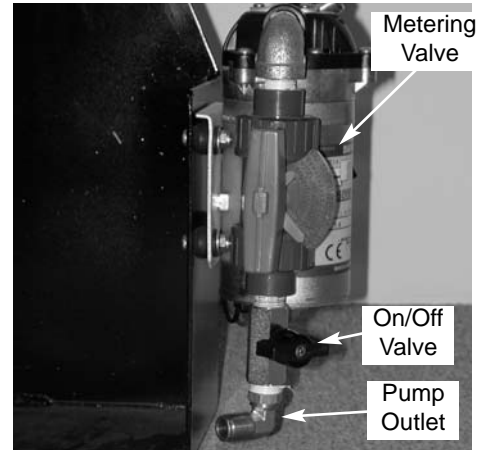

ELECTRICAL HOOK-UP

1. Connect the switch harness to the pump and battery harness at the Packard Weatherpack connections. Be sure to press firmly together until the latching systems become locked. Run the two wire ties provided through the holes in the mounting bracket and secure the connected terminals.
2. Route the battery lead to the battery. Secure the wire where it will not be cut, or bent too sharply. Connect the 12 Volt battery cable to your battery, red clamp to positive (+), black clamp to negative (-). (Refer to the 12 Volt Applicator Hook-Up Diagram.) There is fuse located in the orange holder on the red clamp (+) side of the battery cable. This holder contains a 10 Amp blade type fuse.
3. Route the remote switch to the desired location. You can mount the switch by drilling two 3/16" holes and securing with two 3/16" bolts or you can mount it by drilling one 5/16" hole and securing it with a 1/4" bolt is also an option. If it is preferred, it can be hand held operated.

Application System - Installation and Mounting

Section B

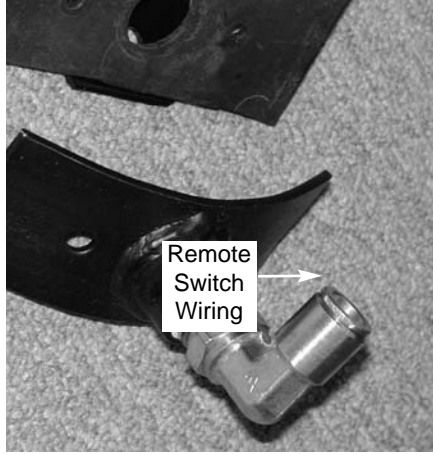

Disconnected Remote Switch

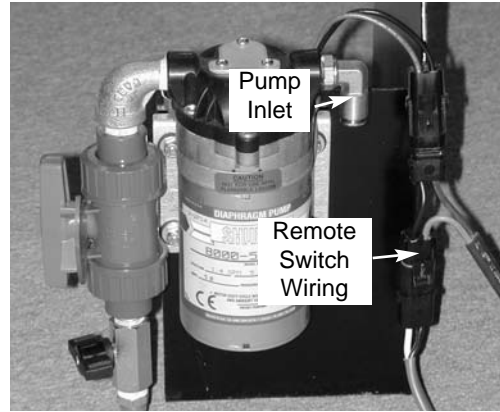

Connected Remote Switch

12 VOLT APPLICATOR HOOKUP FOR VARIOUS BATTERY ARRANGEMENTS

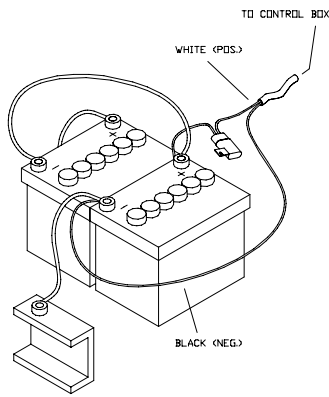

24-VOLT SYSTEM USING TWO 12-VOLT BATTERIES

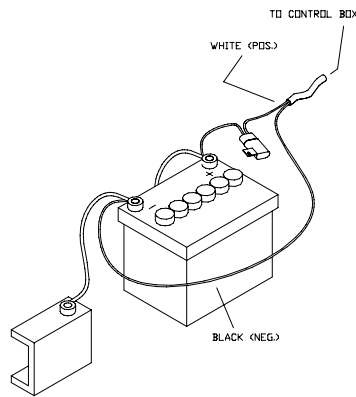

ONE 12-VOLT BATTERY

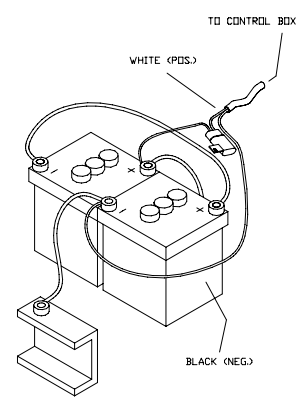

12-VOLT SYSTEM USING TWO 6-VOLT BATTERIES

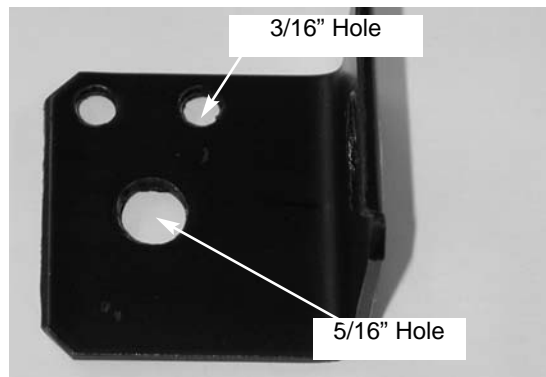

Remote Switch Mounting Bracket

Application System - Operation Instructions

Section C

Application System - Operation Instructions

Section C



IMPORTANT

Inspect unit thoroughly for screws, bolts, fittings, etc., which may have come loose during shipping.

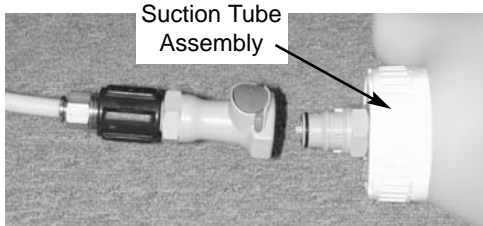
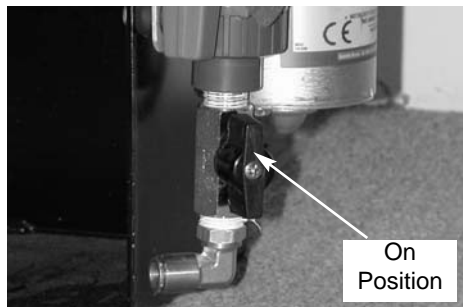
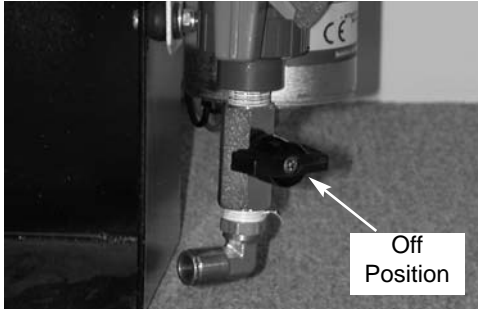

INSPECT UNIT

System Overview

The application system is comprised of the following assemblies and components:

- Jug Holder
- Auger Mount Bracket
- Pump System
 - Pump
 - Suction Tube Assembly
 - Flow Regulating Valve
 - On/Off Valve
- Remote Switch & Battery Harness

JUG HOOK-UP

1. Turn On/Off Valve to the "OFF" position.
2. Mount a 2 1/2 gallon chemical container on the bracket.
3. Remove the cap from the jug and insert the chemical suction tube assembly in the container and secure it to the jug.
4. Attach the quick coupler to the suction tube assembly.



IMPORTANT

Make sure that the On/Off valve is in the Off position when not in use to prevent siphoning.



IMPORTANT

Make sure that the stainless steel suction tube is fully pressed into the Auto-Lock Coupler on the tube assembly.



Quick Coupler Attached

Application System - Operation Instructions

Section C

APPLICATION



IMPORTANT

Always check the calibration before use. Temperature, chemical viscosity, auger angle, auger capacity, and an inconsistent 12 Volt charging system will affect calibration.

1. Make sure that the jug attached is secure.
2. Turn the On/Off valve to the “On” position.
3. Turn on the auger system, which you are currently mounted to. Make sure that there is seed being transferred through the auger.
4. Turn the remote toggle switch into the “On” position.
5. Turn the remote toggle switch to the “Off” position when the amount of seed to be treated is complete.
6. Turn the On/Off valve to the “Off” position.

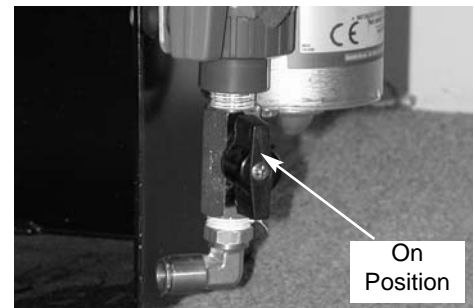
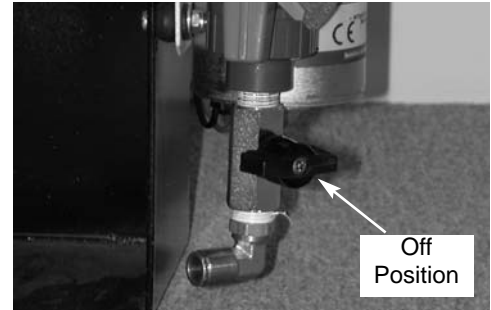

Remote Switch Position



IMPORTANT

System must be cleaned and flushed after each use. (Refer to Section E “Storage”.)



WARNING

Observe all Federal and State EPA regulations and all Local, State and Federal codes and/or laws regarding licensing, handling, storage, transportation, application and waste disposal of chemicals.

Application System - Operation Instructions

Section C

NOTES

Application System - Calibration

Section D

Application System - Calibration

Section D

CALIBRATION



IMPORTANT

Always check the calibration before use. Temperature, chemical viscosity, auger angle, auger capacity, and an inconsistent 12 Volt charging system will affect calibration.

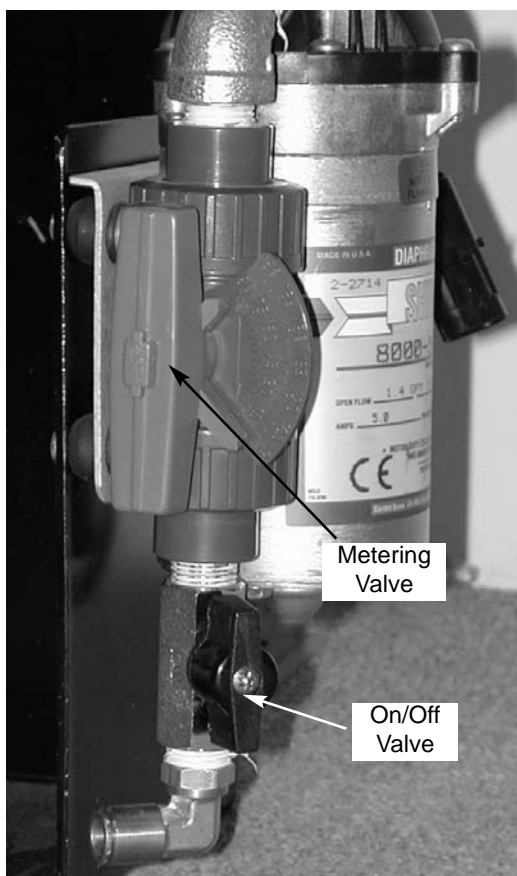

Metering Valve / On-Off Valve

1. It is necessary to determine the volume or weight of seed transported by the auger during a predetermined amount of time. Access to a scale, seed bags or other device to measure the seed is essential.

Example: After operating the auger for one minute, the seed, which was transported, is 10 bushels. Therefore, the auger is delivering 10 bushels of seed per minute.

2. Read the entire chemical label and make sure that you understand the usage and rates to be applied. Take a special note whether the recommended application rate of the chemical use is given in fluid ounces per bushel or in fluid ounces per CWT (100 lb.) of seed.

3. Determine the recommended chemical application rate.

Example: It has been determined that the chemical application rate is 6.8 oz. per 100 lbs. The auger is transporting 10 bushels or 600 lbs. of soybeans in one minute. Therefore it is necessary to catch 40.8 oz of chemical per minute. $600 \text{ lbs} \div 100 \text{ lbs.} = 6 \text{ CWT}$ $6 \text{ CWT} \times 6.8 \text{ oz. per CWT} = 40.8 \text{ oz per minute}$.

4. Remove the discharge hose from the auger bracket and place it into a calibration container. Make sure that you are using the chemical that you will be applying and that the battery cables are connected and the on/off valve is in the on position. Turn on the pump to fill the discharge line with product. Use the calibration guide as a starting point for finding the proper setting on the metering valve. After the discharge line is filled, capture the product in the container over a set time period. 2-3 minutes is suggested.
5. If the required volume of product is not correct, adjust the metering valve and repeat the procedure until the proper product to seed ratio is achieved.
6. Reconnect the discharge line to the auger bracket. You are now ready to treat seed.

Application System - Calibration

Section D

CALIBRATION GUIDE



NOTE

The following is intended to provide a starting point only. Follow Calibration instructions for proper calibration.

Fluctuating temperatures can change the viscosity and flow-ability of chemicals, affecting the calibration setting. Recheck the calibration if extremely high or low temperatures exist. For example: treating in the early morning, when temperatures are cool and then again in the afternoon when the temperature has changed.

There are two calibration arrows on the metering valve with calibration marks that run from 0 to 180. Use the long arrow to set rates on the 90-180 scale and the short arrow to set rates on the 0-90 scale.

Approximate Ounces Metered Per Minute at 65 Degrees Fahrenheit

<u>Metering Valve Calibration Setting</u>	<u>Approximate Oz. Per Minute</u>
0	0
30	6.6
45	13.3
60	26.6
75	40.0
105	46.6
135	53.3
165	56.6
180	60.0

Application System - Calibration

Section D

NOTES

**Application System - Service, Maintenance,
Storage & Troubleshooting**
Section E

Application System - Service, Maintenance, Storage & Troubleshooting

Section E

Service & Maintenance

The primary service issue with this type of application system is cleaning and flushing. It is very important that adequate flushing and rinsing of the system is accomplished after each use.



NOTE

The inside of the auger is coated with chemical and therefore should not be used to convey grain for feed, food, or oil at any time. If you wish to auger seed and do not wish to treat it, disengage the pump and close the on/off valve.

Clean Up

1. When you are finished treating seed, remove the suction tube assembly from the chemical container. Disconnect the discharge tubing from the elbow fitting on the auger bracket and place it in the chemical container.
2. Turn the remote switch on in order to empty the chemical line and pumps.
3. Once the chemical lines and the pump are empty, place the suction tube assembly into a pail containing 1-2 gallons of clean water. Turn the remote switch on and pump the clean water through the system to flush the chemical lines, the pump, the on/off valve



IMPORTANT

All chemical contaminated rinse material must be collected and disposed of according to product label instructions and in accordance with all Local, State, and Federal Laws.

and the metered ball valve. Repeat the procedure as needed until all lines and pump are clean.

Storage

1. If the TNT is going to be stored in sub-freezing temperatures, flush with RV Antifreeze to prevent freezing.
2. Coil all lines and hoses and store them in a clean, dry location until the next season's use.

Troubleshooting

The following chart will assist you with the most common troubleshooting issues that are encountered on this system. In addition to the following chart, your best tool for troubleshooting is a well trained operator. Read and understand this manual prior to operating or attempting to troubleshoot this system.

If you cannot rectify the problem on your own, contact Redball, LLC via the following:

Application System - Service, Maintenance, Storage & Troubleshooting

Section E

SYMPTOM	PROBABLE CAUSE(S)	CORRECTIVE ACTION
Pump does not run when switch is turned on.	Battery Voltage is too low.	Test Voltage of the battery and make sure it is at least 12 Volts DC.
	Connections are not good at the battery	Readjust clamps on the battery and/or clean the battery posts and clamps.
	Packard terminals are not plugged in completely.	Disconnect the terminals, visually inspect them and plug them back in until fully locked.
	No fuses or a bad fuse in fuse holder.	Put in 10 AMP blade fuse in the fuse holder.
Pump runs but produces no flow.	Pump is not primed.	Make sure that the whole suction tube assembly strainer is flooded with liquid.
	Pump is sucking air into the inlet side.	Make sure that aluminum tubing (item 2) is fully pressed into the coupling (item 34). Refer to reference part drawing for item numbers.
	Valves are shut off.	Make sure the on/off valve and the metering valve are both in the open position.
Pump produces only very small amounts of flow.	Lines are kinked.	Make sure that there are no sharp bends or kinks in the line. Also make sure that they are not flattened or smashed.
	Pump is sucking air into the inlet side.	Make sure that aluminum tubing (item 2) is fully pressed into the coupling (item 34). Refer to reference part drawing for item numbers.
	Metering Valve closed too far.	Adjust
	Bad battery connections or low battery	Check Battery voltage and readjust clamps.

**Application System - Service, Maintenance,
Storage & Troubleshooting**
Section E

NOTES

Application System - Parts & Schematics

Section F

Application System - Parts & Schematics

Section F

Description: T-N-T Seed Treater Breakdown Assembly

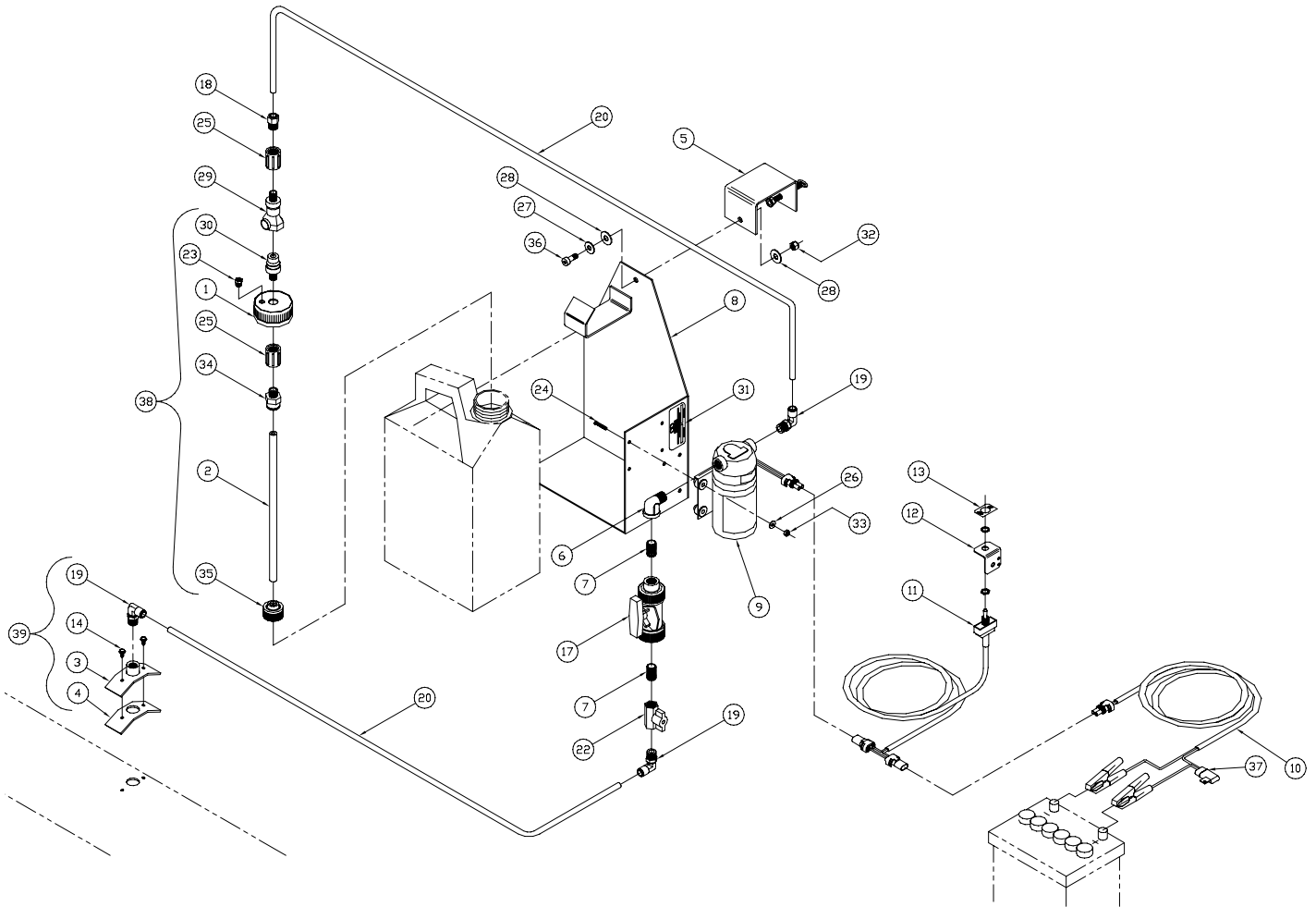

Item#	Part #	Description	Quantity
1	001707	Cap; Modified	1
2	001709	Tube, Draw, 1/2" x 12 1/2" Alum.	1
3	001710	Saddle Strap Weld; TNT	1
4	001712	Gasket; Saddle -TNT	1
5	001713	Bracket Weld; Seed Treater	1
6	002604	St Ell; 3/8 Gal V Pipe	1

Application System - Parts & Schematics

Section F

Description: T-N-T Seed Treater Breakdown Assembly

Item#	Part #	Description	Quantity
7	002605	Nipple; 3/8 Short, Gal V.	2
8	003949	Jug Holder Weld; TNT	1
9	003953	Wiring; Motor, Ass'y	1
10	003954	Cable; Battery Lead	1
11	003955	Wiring; Switch, Cable	1
12	003959	Mount; Remote Switch	1
13	003966	Decal; Remote Switch	1
14	1008KV	Screw, #10 x 1/2 Self Tap S.S.	2
15*	3NS12	Strap; Black 11 1/4"	2
16*	3NS8	Strap; Black 7 1/4"	1
17	4030-06003	Valve; 3/8" Metering Ball	1
18	4030-06005	HB-3/8 MPT x 3/8 Aut-Lok SW-BR	1
19	4030-06006	EI; 3/8MPT x 3/8Aut-Lok 90BR-S	3
20	4030-060014	Tubing; 3/8 Yellow UPC-2354	
21*	725110	Terminal; Butt Connector; 12/10	2
22	90FFB38	Valve; 3/8 Female NPT, Brass	1
23	9833K21	Vent; Breather	1
24	BM-10/32 x 125	Bolt Mach. 10/32 x 1 1/4" Ph Pan	4
25	CPLG038	Coupling; 3/8" Pipe	2
26	FW-#10	Flatwasher; #10	4
27	FW-031	Flatwasher; 5/16" Flatwasher	1
28	FW-038	Flatwasher; 3/8" Flatwasher	2
29	HFCD 106-12	Valve, Quick, 3/8 MPT, w/Shutoff	1
30	HFDC 246-12	Insert; Quick, 3/8 MPT w/Shutoff	1
31	LC028	Serial Plate	1
32	LN-031-NI	Locknut; 5/16", Nylon Insert	1
33	LN-10/32-NI	Locknut; 10/32", Nylon Insert	4
34	MC12038	Coupling; 1/2 x 3/8 Auto Loc Str	1
35	RVF663-20	Strainer; 1/4" PVC Suction	1
36	SS038-038-031	Shoulder Screw; 3/8 x 3/8 x 5/16	1
37	46210	Fuse, 10 Amp, Blade Type	1
38@	005743	Suction Tube Ass'y Kit	
39@	005527	TNT Auger Mount Kit	

* = Not Shown

@ = Optional

Application System - Parts & Schematics

Section F

NOTES

Application System - Warranty

Section G

Application System - Warranty

Section G

NEW PRODUCT WARRANTY

Redball, LLC warrants each new Redball® product to be free under normal use and service from defects in workmanship and materials for a period of one (1) year from the date of first use. This warranty shall be fulfilled by the repairing or replacing free of charge any part that shows evidence of defect or improper workmanship, provided the part is returned to Redball, LLC within thirty (30) days of the date that such defect or improper workmanship is discovered, or should have been discovered. Parts shall be returned through the selling representative and the buyer must pre-pay transportation charges. No other express warranty is given and no confirmation, by words or action, shall constitute a warranty.

Redball, LLC limits its warranty to only those products manufactured by Redball, LLC and does not warrant any part or component not manufactured by Redball, LLC, such parts or components are subject to their manufacturer's warranties, if any. This warranty shall not apply to parts, which are subjected to accident, alteration, or negligent repair or use.

Redball, LLC will not be responsible for repairs or replacements, which are necessitated, in whole or part, by the use of parts not manufactured by or obtainable from Redball, LLC. Customer acknowledges that he/she is not relying on Redball, LLC's skill or judgment to select or furnish goods for any particular purpose and that there are no warranties which are not contained in this agreement.

This warranty shall not be interpreted to render Redball liable for injury or damages of any kind or nature to person or property. This warranty does not extend to loss of crops, or any expense or loss incurred for labor, substitute machinery, rental or for any other reason.

Labor to perform warranty repairs to Redball, LLC manufactured products will be paid only at the discretion of Redball, LLC. If labor is payable, the time to perform a warranty repair and the amount paid will be determined per the job by Redball, LLC. Redball, LLC issues credit to the dealer or distributor's account for warranty labor. Invoices sent to Redball, LLC for unauthorized repairs will not be approved or paid by Redball, LLC.

If the customer decides to purchase a replacement component before the warranty disposition is known, Redball LLC will bill the customer for components shipped to replace suspected warranty components. If the manufacturer's warranty covers the suspect components, Redball LLC will credit the replacement invoice. If the component is not deemed a warranty issue, the replacement invoice is subject to the terms of the invoice.

This warranty is subject to any existing conditions of supply, which may directly affect our ability to obtain materials or manufacture replacement parts.

In no event shall Redball, LLC, contract or warranty liability exceed the purchase price of the product.

Redball, LLC shall not be liable for damages, including special, incidental or consequential damages arising from or in connection with the performance of the equipment or its use by customer, and Redball, LLC shall not be liable for any special, incidental or consequential damages arising from or in connection with Redball, LLC's failure to perform its obligations hereunder. Redball, LLC entire liability and the customer's exclusive remedy shall be repair or replacement of parts covered under this warranty. This warranty is in lieu of all other warranties, expressed or implied.

The Employees of



would like to thank you for purchasing the Redball®
Application System. We are proud of our quality and
believe this product will exceed your expectations!

For More Information Contact:

Redball, LLC
140 30th Ave. SE
Benson, MN 56215
1-877-332-2551 (Toll Free)
FAX: 320-843-2503